

WPA

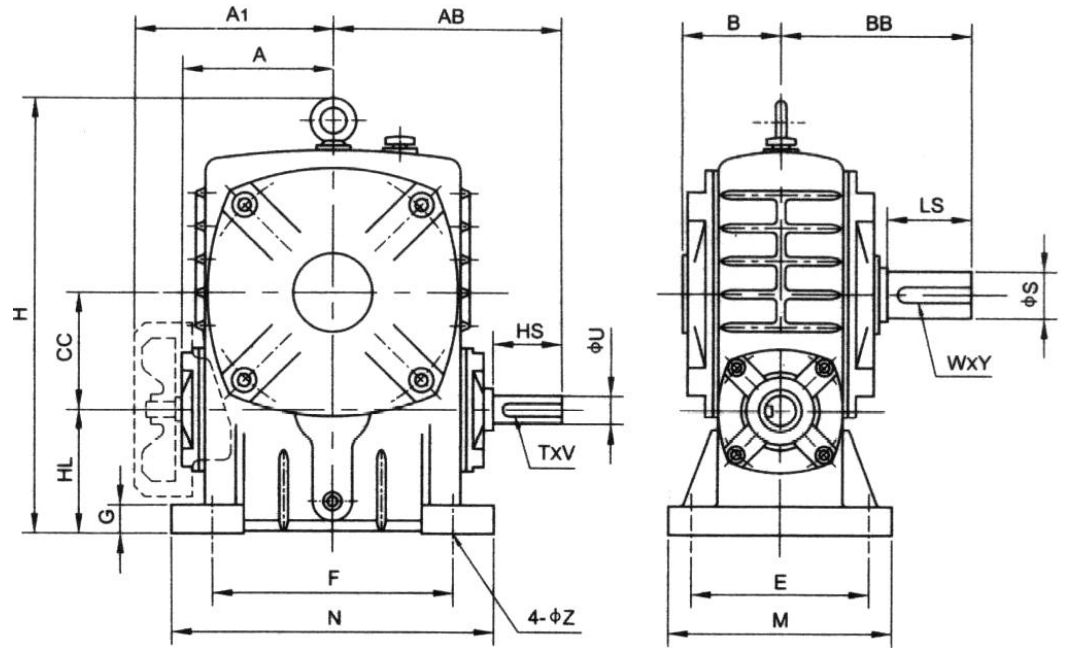

| Size | Ratio | A | A ₁ | AB | B | BB | CC | E | F | M | N | H | HL | LL | G | Z | Input Shaft | | | Output Shaft | | |
|------|-------|-------|----------------|-------|------|-------|-------|-------|-------|-------|-------|-------|------|-------|------|------|-------------|------|----------------|--------------|------|---------------|
| | | | | | | | | | | | | | | | | | U | HS | T x V | S | LS | W x Y |
| 40 | 5:1 | 2.24 | | 3.35 | 1.57 | 2.91 | 1.575 | 2.76 | 3.15 | 3.54 | 3.94 | 5.31 | 1.57 | 3.15 | 0.47 | 0.39 | 0.500 | 1.10 | 1/8 1/16 | 0.625 | 1.38 | 3/16 -3/32 |
| 50 | | 2.76 | | 4.13 | 2.08 | 3.82 | 1.969 | 3.74 | 4.33 | 4.72 | 5.51 | 7.09 | 1.97 | 3.94 | 0.59 | 0.43 | 0.625 | 1.18 | 3/16 3/32 | 0.750 | 1.57 | 3/16 3/32 |
| 60 | 10:1 | 3.09 | | 4.72 | 2.20 | 4.33 | 2.362 | 4.13 | 4.72 | 5.12 | 5.91 | 8.27 | 2.36 | 4.72 | 0.70 | 0.43 | 0.750 | 1.57 | 3/16 3/32 | 1.000 | 1.97 | 1/4-- -1/8 |
| 70 | | 3.76 | | 5.51 | 2.52 | 5.12 | 2.756 | 4.53 | 5.91 | 5.91 | 7.48 | 9.57 | 2.76 | 5.51 | 0.79 | 0.59 | 0.875 | 1.57 | 3/16 3/32 | 1.125 | 2.36 | 1/4 1/8 |
| 80 | 15:1 | 4.11 | | 6.30 | 2.85 | 5.51 | 3.150 | 5.31 | 7.09 | 6.69 | 8.66 | 10.75 | 3.15 | 6.30 | 0.79 | 0.59 | 1.125 | 1.97 | 1/4-- -1/8 | 1.375 | 2.56 | 5/16 5/32 |
| 100 | | 4.78 | | 7.00 | 2.95 | 6.10 | 3.937 | 6.10 | 8.66 | 7.48 | 10.24 | 13.39 | 3.94 | 7.87 | 0.98 | 0.59 | 1.375 | 1.97 | 5/16 5/32 | 1.500 | 2.95 | 3/8 3/16 |
| 120 | 30:1 | 6.10 | 8.26 | 9.06 | 4.02 | 7.28 | 4.724 | 7.09 | 1.24 | 9.06 | 12.60 | 16.14 | 4.72 | 9.45 | 1.18 | 0.71 | 1.500 | 2.56 | 3/8-- -3/16 | 1.750 | 3.35 | 3/8 3/16 |
| 135 | | 6.89 | 9.06 | 10.24 | 4.33 | 8.27 | 5.135 | 7.87 | 11.42 | 9.84 | 13.78 | 18.50 | 5.31 | 10.63 | 1.18 | 0.71 | 1.625 | 2.95 | 3/8 3/16 | 2.250 | 3.74 | 1/2 1/4 |
| 155 | 50:1 | 7.64 | 10.24 | 11.89 | 5.20 | 9.92 | 6.102 | 8.66 | 12.60 | 11.02 | 15.35 | 19.49 | 5.31 | 11.42 | 1.38 | 0.79 | 1.625 | 3.35 | 3/8 3/16 | 2.500 | 4.33 | 5/8 5/16 |
| 175 | | 8.78 | 11.42 | 12.80 | 5.71 | 10.31 | 6.890 | 9.84 | 13.78 | 12.20 | 16.93 | 21.89 | 6.30 | 13.19 | 1.46 | 0.79 | 1.875 | 3.35 | 1/2 1/4 | 2.750 | 4.33 | 5/8 5/16 |
| 200 | 60:1 | 9.61 | 12.60 | 13.78 | 6.89 | 12.01 | 7.874 | 11.42 | 15.35 | 14.17 | 18.90 | 24.61 | 6.89 | 14.76 | 1.65 | 0.87 | 2.000 | 3.74 | 1/2-- -1/4 | 2.875 | 4.92 | 3/4 3/8 |
| 250 | | 11.42 | 16.00 | 16.54 | 7.87 | 14.17 | 9.843 | 14.96 | 18.90 | 18.11 | 22.05 | 29.72 | 7.87 | 17.72 | 1.89 | 1.06 | 2.250 | 4.33 | 1/2 1/4 | 3.500 | 6.10 | 7/8 7/16 |